

THIS DRAWING & DESIGN IS THE SOLE PROPERTY OF VMS & SHALL NOT BE COPIED, TRACED OR REPRODUCED BY ANY MEANS WITHOUT PRIOR WRITTEN CONSENT OF THE FIRM.

GENERAL NOTES :

1. ALL THE DIMENSIONS ARE UNFINISHED DIMENSIONS.
2. ALL DIMENSIONS ARE IN MM AND LEVELS ARE IN MT, UNLESS OTHERWISE MENTIONED.
3. ALL THE DIMENSIONS SHALL BE READ & NOT TO BE MEASURED.
4. IN CASE OF ANY DISCREPANCY, BRING IT TO THE NOTICE OF THE ENGINEER IMMEDIATELY.
5. DETAIL DRAWING PRECEDES THE GENERAL DRAWING

IMPORTANT NOTE :

1. FOR LOCATION OF PERCOLATING WELL REFER DRAWING NO. C.D.101.
2. PERFORATION / SLOT SIZE ON M.S PIPE WILL BE 1/16".
3. GRAVEL PACKING WILL BE DONE BY GRAVEL SIZE 3/16" TO 5/16".
4. CLAY BALL PACKING & CEMENT SEALING AS PER SITE CONDITION.
5. AT EVERY TWO TO THREE YEARS S.S. FILTER WILL BE WASH & FILLED UP AGAIN.

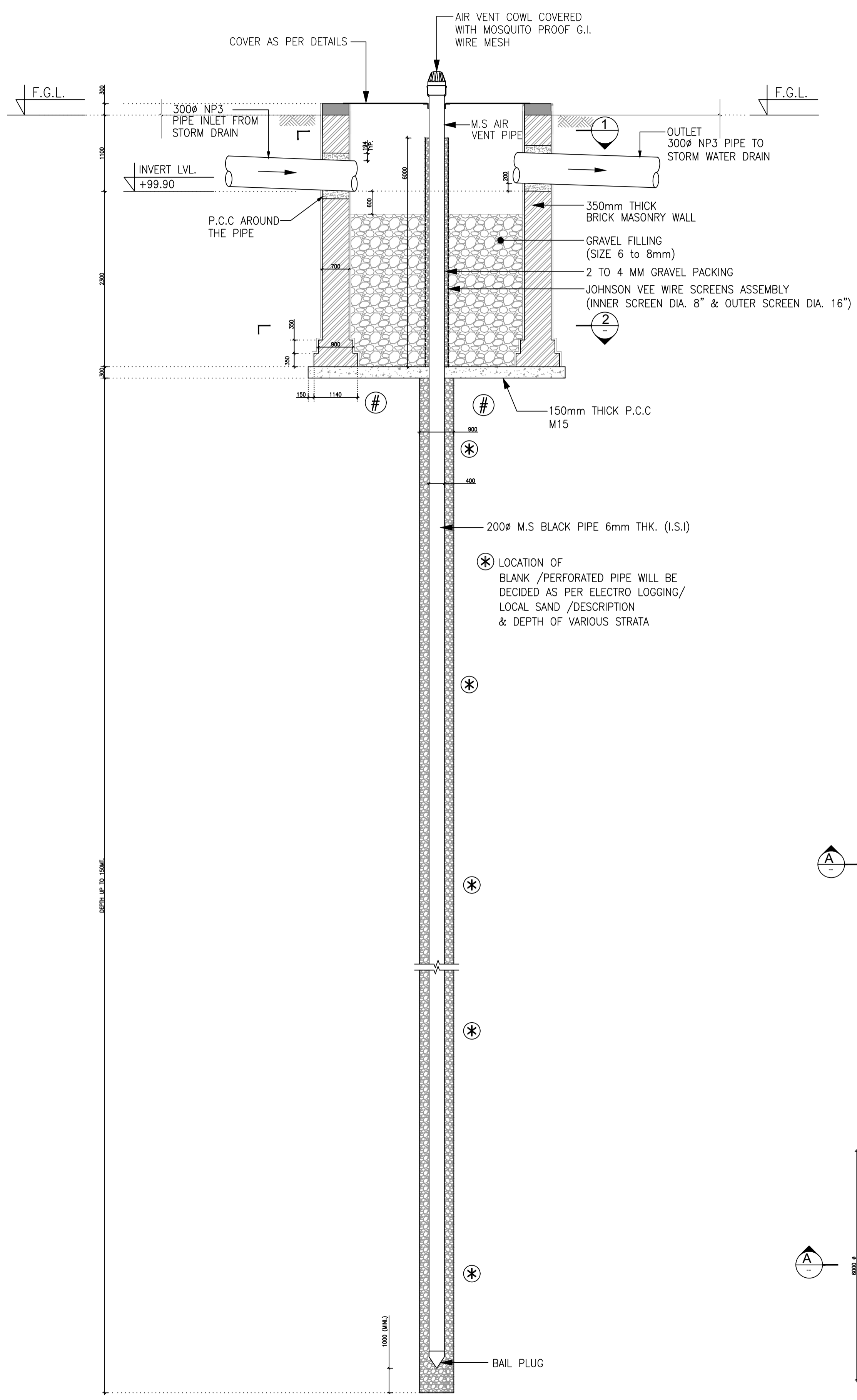

A SECTION THROUGH WELL (R.W. -02 TO R.W. -17)
SCALE 1:50

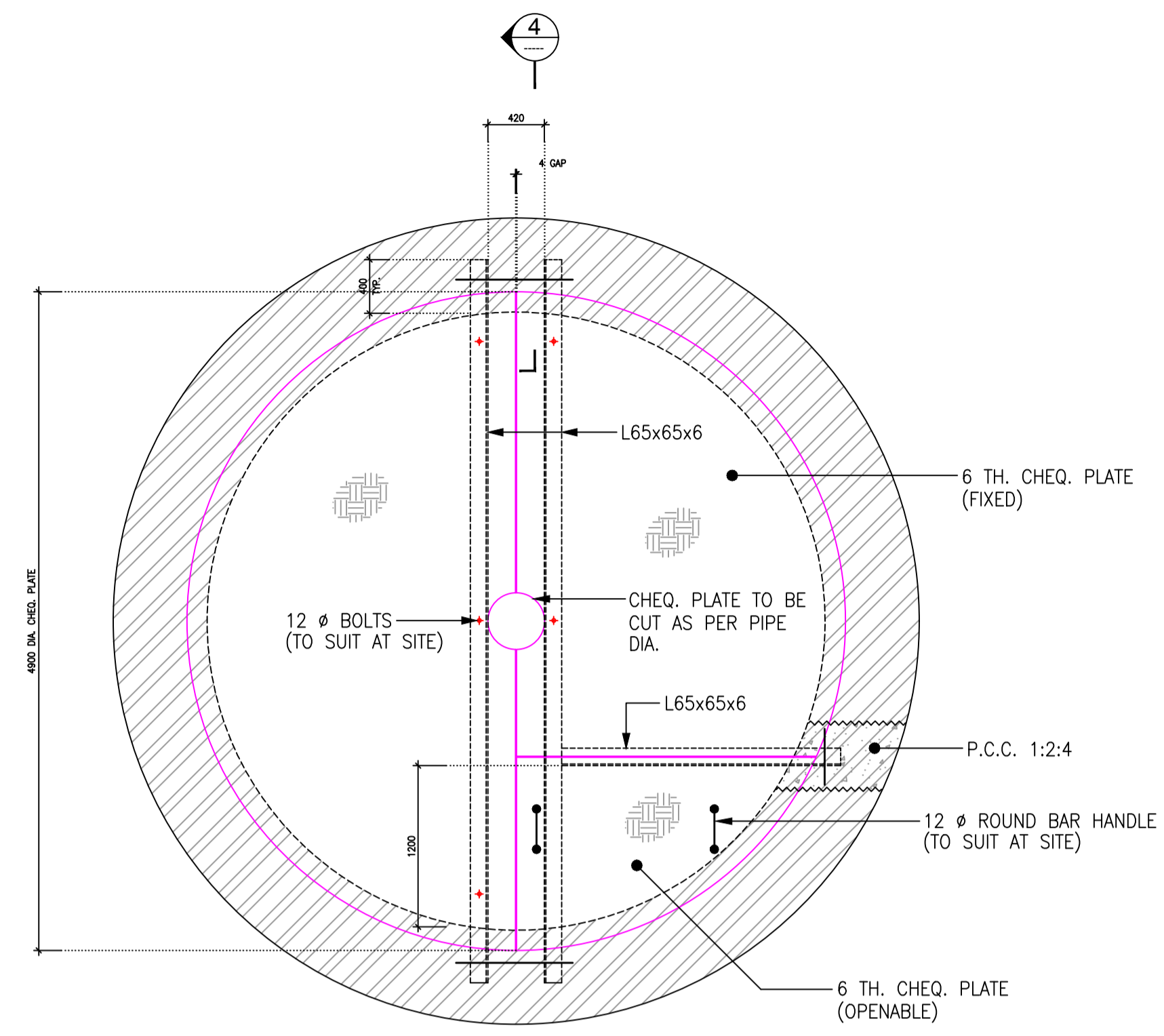

3 DETAILS OF TOP COVER
SCALE 1:25

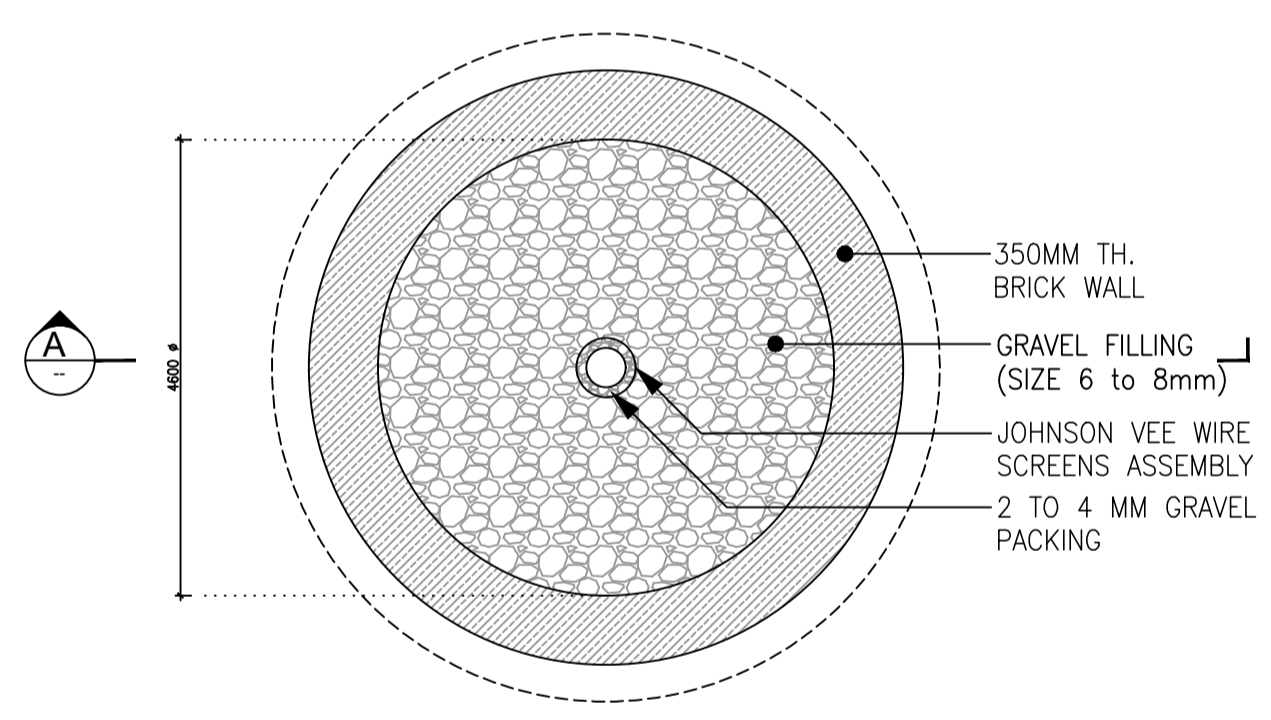

2 PLAN OF PERCOLATING WELL
SCALE 1:50

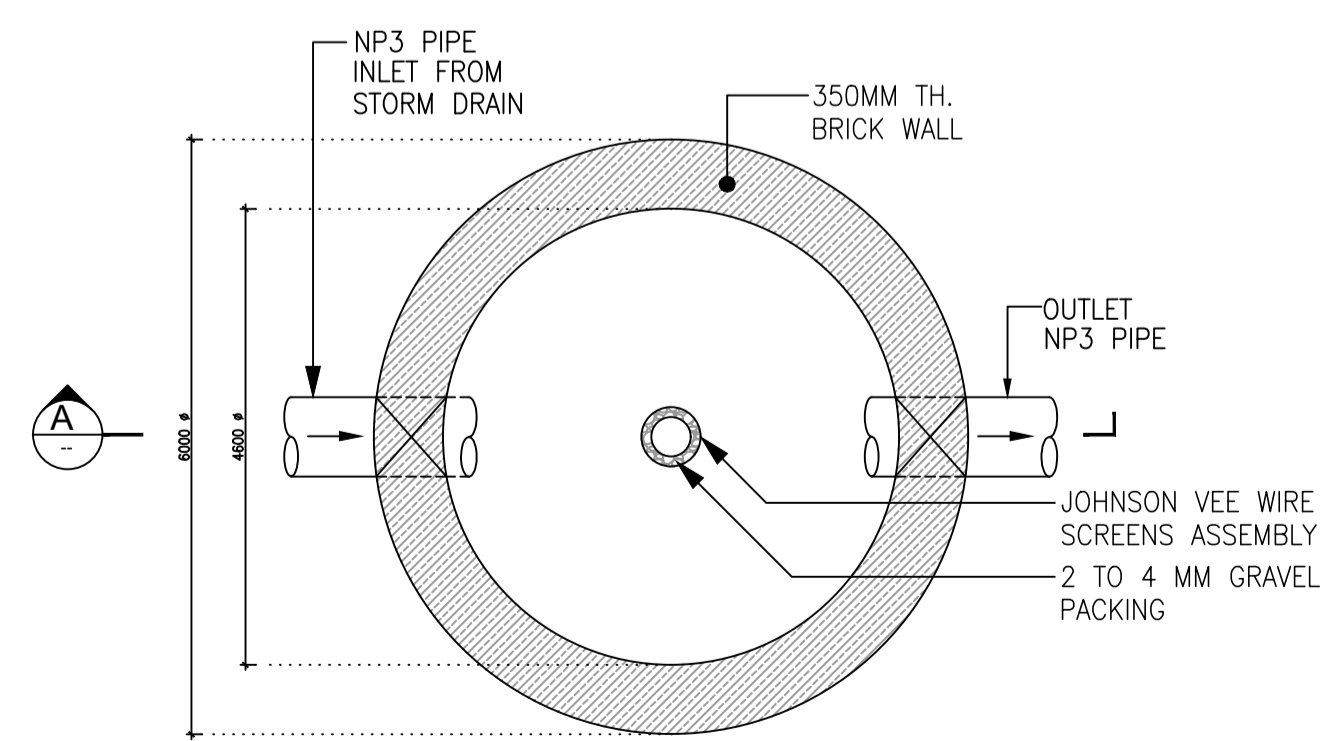

1 PLAN OF PERCOLATING WELL
SCALE 1:50

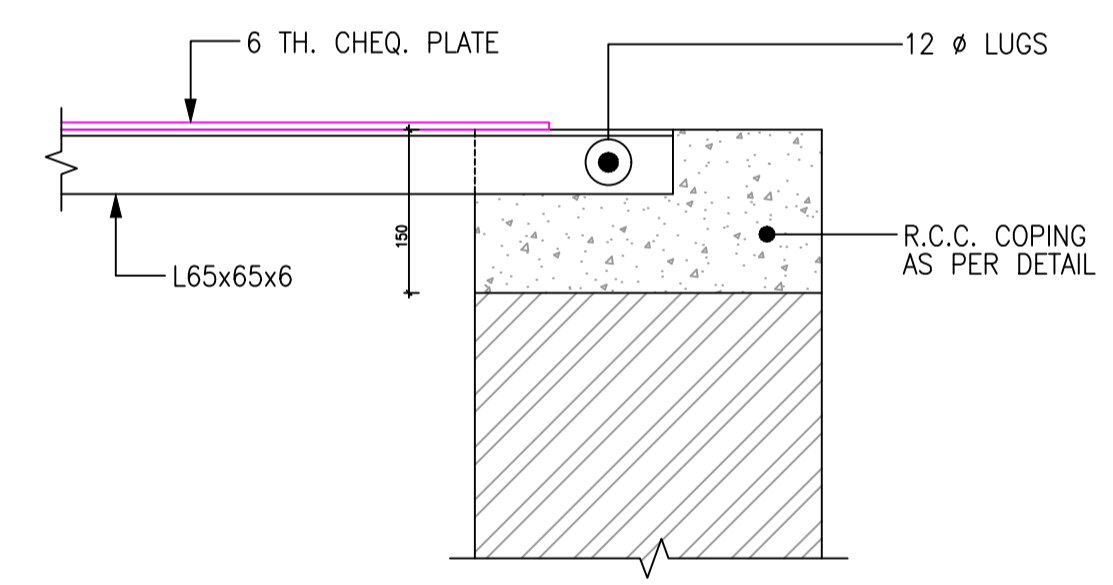

4 SECTION
SCALE 1:10

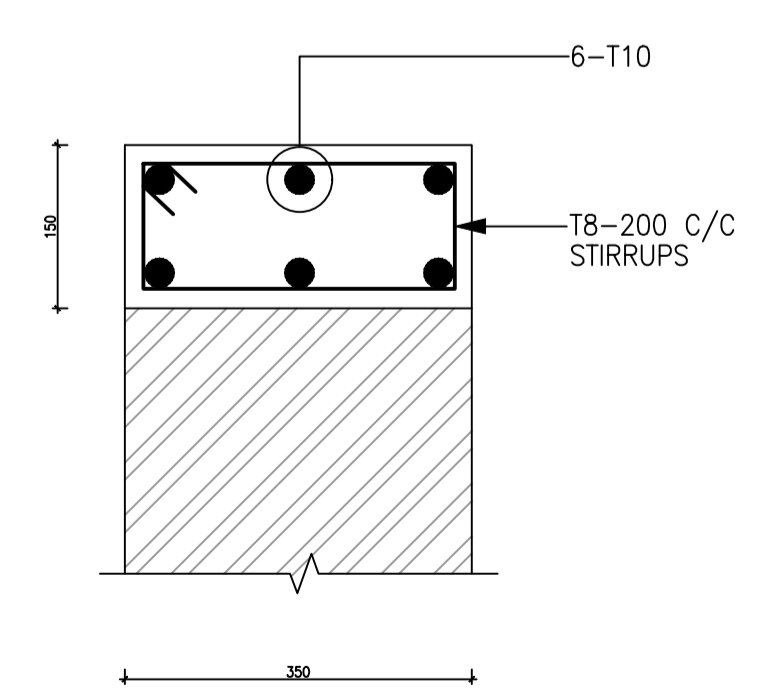

5 DETAILS OF R.C.C. COPING
SCALE 1:10

FOR TENDER

NO.	DATE	DESCRIPTION	DRAWN BY	CHECKED BY

REVISION HISTORY

KEY PLAN SCALE: N.T.S.

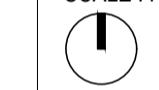

REFERENCE DRAWINGS :

01. ARCHITECTURAL :	-
02. STRUCTURAL :	-
03. HVAC :	-
04. ELECTRICAL :	-
05. UTILITIES :	-

DETAILS FOR PERCOLATING WELL

PMC
Technopak Advisors Pvt. Ltd.
Gurgaon.

fanidhar
MEGA FOOD PARK - AT MUDARDA, MEHSANA
khat se bazaar tak...

PROJECT NO.	SCALE :	DRAWN :	SHAILESH
2017	NTS	CHECKED :	KEVAL
	DATE :	APPROVED :	DINESH T.
	30-11-2017	COORDINATION CHECKED :	ROMIL

vms ENGINEERING & DESIGN SERVICES (P) LTD.
CHITRAKOOT FLATS, BEHIND TIMES OF INDIA, OFF ASHRAM ROAD, AHMEDABAD-380 009. PHONE: +91 (079) 2698-8629/4488, 40236236
ENGINEERING + ARCHITECTURE FAX: +91 (079) 2658 3596 WWW.VMSCONSULTANTS.COM

SHEET SIZE	DRAWING NO.	TENDER	REVISION:
A1	T.CD.102	T	R0